

RECTANGULAR BELLOW SPECIFICATION SHEET

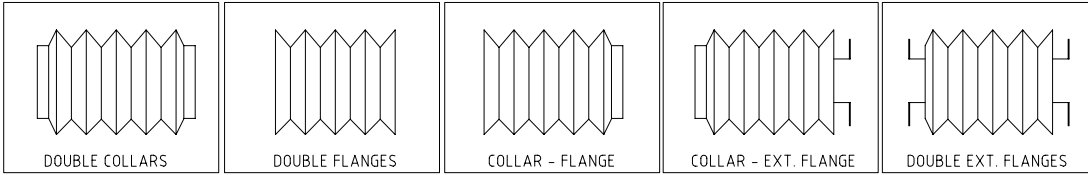

ORDERING SPECIFICATIONS

External Dimensions	L x H	x
Internal Dimensions	l x h	x
Extended Length Excluding Cuffs	A1.	
Closed Length Excluding Cuffs	A2.	
Cuff Size Required	B1.	
Cuff Length Required for Fastening	C1.	
Cuff Size Required	B2.	
Cuff Length Required for Fastening	C2.	
Material Type	_____	
Special Requirements	_____	

CUSTOMER DETAILS

Company Name: _____

Contact Name: _____

Address: _____

Phone: _____ Fax: _____

Qty: _____ **Cost Per Unit: \$** _____

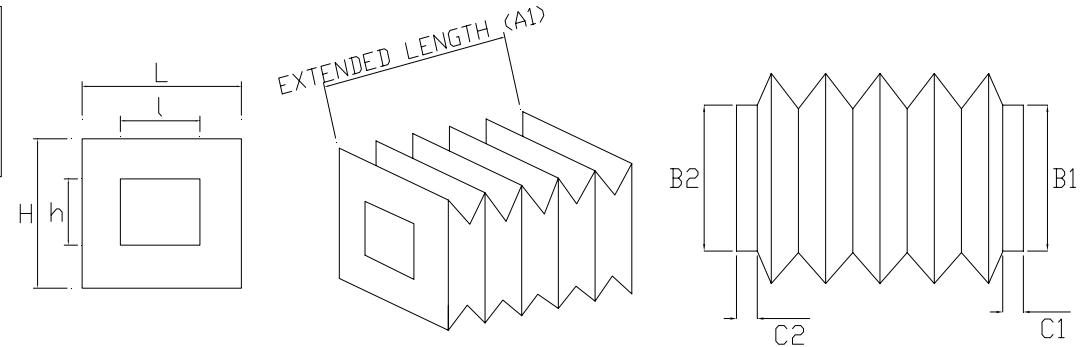

- | | | |
|---|--------------------------------------|---------------------------------------|
| <input type="checkbox"/> Indoor Use | <input type="checkbox"/> Outdoor Use | <input type="checkbox"/> Humidity |
| <input type="checkbox"/> Dryness | <input type="checkbox"/> Heat | <input type="checkbox"/> Dust / Sand |
| <input type="checkbox"/> Welding Splashes | <input type="checkbox"/> Saltwater | <input type="checkbox"/> Rust Action |
| <input type="checkbox"/> Abrasive Action | <input type="checkbox"/> Magnetic | <input type="checkbox"/> Vacuum |
| <input type="checkbox"/> Chips Large | <input type="checkbox"/> Chips Small | <input type="checkbox"/> Coolant Type |
| <input type="checkbox"/> Oil Type | | |

Working Temperature (In °C)

Min
 Max
 Average

SPECIAL FEATURES AVAILABLE ON REQUEST

- Internal Support Rings For Horizontal Application
- External Tie Straps for Vertical Application
- Binder on Convolution Joins, Inside & Out
- Double Stitch on Cuff Connections
- Flange Connections, One End / Both Ends